

Simplified Controller

INSTALLATION INSTRUCTIONS

Part#: 22805-RGBW-00

INSTALLATION CONSIDERATIONS

- The simplified RGBW controller is part of the ITC VersiColor line of RGB/RGBW controllers and lighting products (purchased separately). Refer to individual product install instructions for additional considerations.
- Disconnect power before installing, adding or changing any component.
- To avoid a hazard to children, account for all parts and destroy all packing materials.
- This device complies with part 15 Class B of the FCC rules. Operation is subject to the following two conditions:
 - This device may not cause harmful interference
 - This device must accept any interferences received, including interference that may cause undesired operation
- This controller is capable of sourcing 3A of current per color, limited to 10A total. Example configurations include, but are not limited to:
 - Up to 24 feet of RNLL diffused tape light
 - 16.5 feet of RNLL diffused tape light, six lit cup holders and ten courtesy lights

1. System Connections

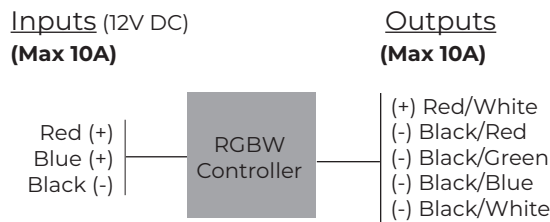

CONTROLLER WIRE LAYOUT

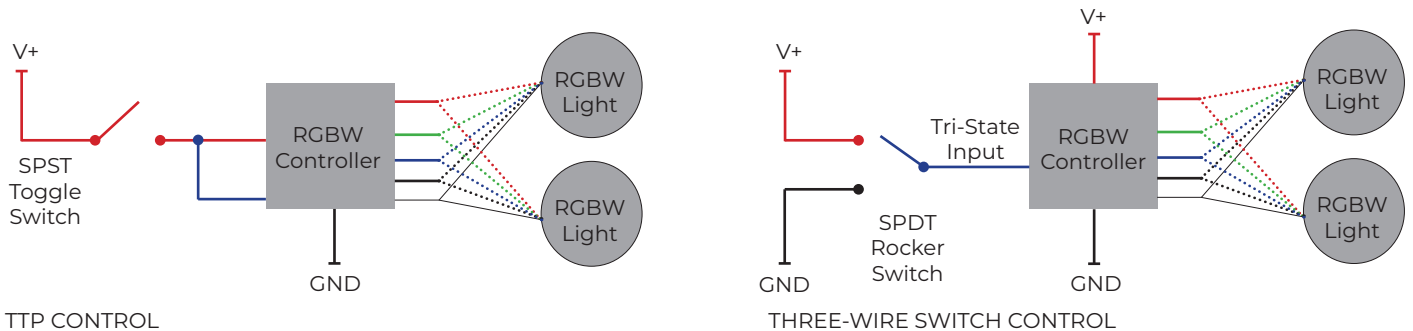

2. System Control

TTP CONTROL

To enable TTP control, connect the input wire to V+

Brightness Control:

When the controller is turned on in TTP control mode, the connected lights will start at minimum brightness and increase in brightness over five seconds. Cycling (turning off and back on) the connected switch will keep the light at that brightness level.

Color Control:

After the brightness has been selected or after five seconds has elapsed, cycling the connected switch will cycle through the available preset colors.

THREE-WIRE SWITCH CONTROL

To enable three-wire switch control, connect the input wire to a momentary rocker switch (MOM-OFF-MOM) so that it is in the off idle state. The other two pins of the rocker switch should be connected to GND and V+. The controller can be controlled by the rocker switch as follows:

V+	Hold for >1 second	Toggle controller ON/OFF
	Tap	<i>Solid Mode:</i> Cycle through colors <i>Fade Mode:</i> Cycle through fades
GND	Hold for >1 second	Toggle between solid and fade modes
	Tap	<i>Solid Mode:</i> Cycle through brightness levels <i>Fade Mode:</i> Cycle through fade speeds



3030 Corporate Grove Dr.
Hudsonville, MI 49426
Phone: 616.396.1355
itc-us.com

For warranty information please visit www.itc-us.com/warranty-return-policy
DOC #: 710-00172 · Rev C · 09/18/24

EMI Noise Considerations

Installation Considerations for Preventing EMI Noise

Electromagnetic interference (EMI) is any unwanted signal which is either radiated (thru air) or conducted (thru wires) to electronic equipment and interferes with the proper operation and performance of the equipment.

All electrical/electronic components that have varying or switching currents, such as RGB lighting, create Electromagnetic interference (EMI noise). It is a matter of how much EMI noise they produce.

These same components are also susceptible to EMI, especially radios and audio amplifiers. The unwanted audible noise that is sometimes heard on a stereo system is EMI.

WHAT IS EMI NOISE?

1. Turn off LED light(s)/controller(s)
 2. Tune the VHF radio to a quiet channel (Ch 13)
 3. Adjust the radio's squelch control until the radio outputs audio noise
 4. Re-adjust the VHF radio's squelch control until the audio noise is quiet
 5. Turn on the LED light(s)/controller(s) – If the radio now outputs audio noise then the LED lights may have caused the interference.
 6. If the radio does not output radio noise then the problem is with another part of the electrical system.
- If EMI is observed the following steps should help isolate the problem.

DIAGNOSING EMI NOISE

GROUNDING (BONDING) : How each component is connected and routed to power ground is important. Route the ground of sensitive components back to the battery separately. Eliminate ground loops. Once the EMI noise is isolated the following steps can be used to help prevent and lessen the effect of the noise.

CONDUCTED & RADIATED SOLUTIONS

SEPARATION : Physically separate and mount the noisy components away from sensitive components. In the wire harness, separate the sensitive wires from the noisy wires.

FILTERING : Add filtering to either the device creating the noise or the sensitive device.

Filtering may consist of power line filters, common-mode filters, ferrite clamps, capacitors and inductors.

RADIATED SOLUTIONS

SHIELDING :

Shielded cables can be used. Shielding the component in a metal enclosure is also an option.

PREVENTING EMI NOISE

If you continue to experience EMI issues please contact your ITC sales representative.

